

Power Steering Pump — 4.6L

Special Tool(s)

 ST1444-A	Installer Set, Teflon® Seal 211-D027 (D90P-3517-A) or equivalent
---	--

Material

Item	Specification
MERCON® V Automatic Transmission Fluid XT-5-QM (or XT-5-QMC) (US); CXT-5- LM12 (Canada)	MERCON® V

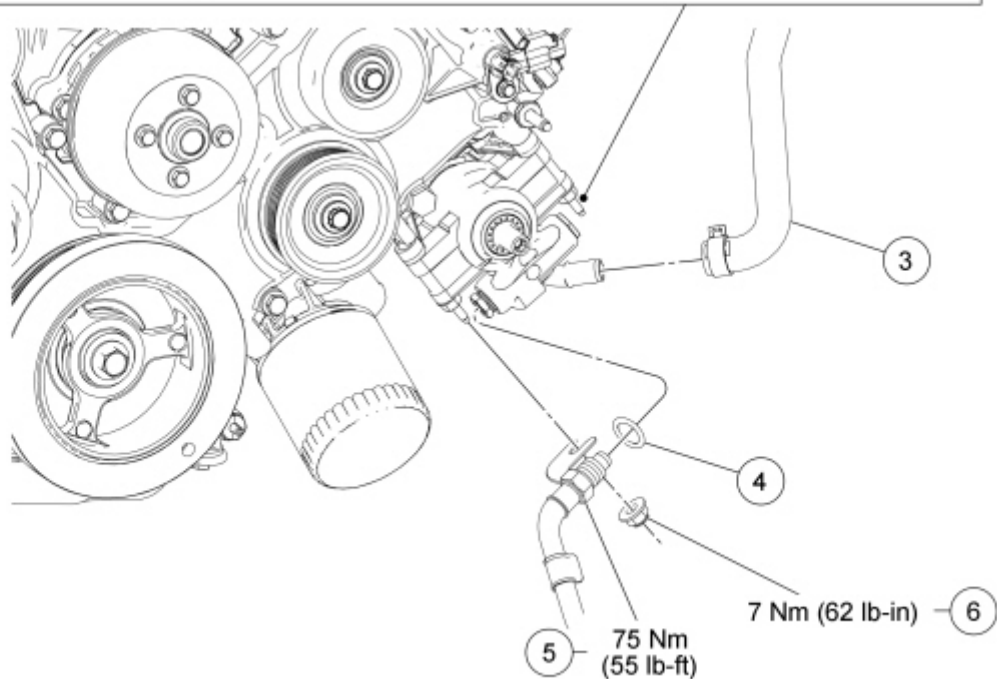
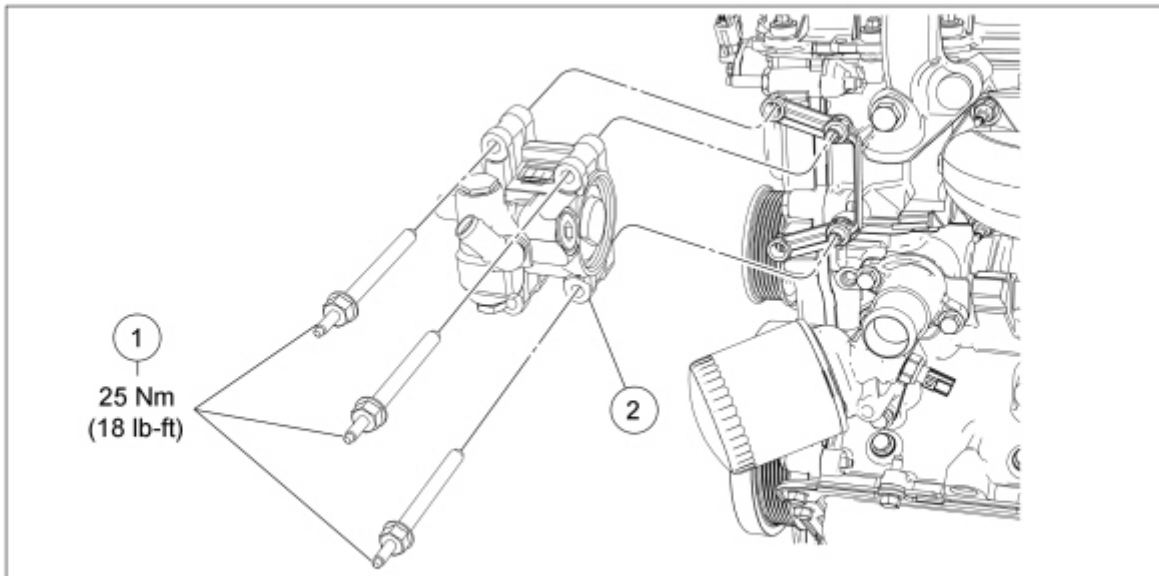

N0110606

Item	Part Number	Description
1	W707225	Power steering pump bolts (3 required)
2	3A674	Power steering pump
3	3691	Power steering pump supply hose
4	388898	Teflon® seal
5	—	Pressure line-to-pump fitting (part of 3A719)
6	N805320	Pressure line bracket-to-pump stud nut

Removal and Installation

NOTICE: When repairing the power steering system, care should be taken to prevent the entry of foreign material or failure of the power steering components may result.

1. With the vehicle in NEUTRAL, position it on a hoist. For additional information, refer to [Section 100-02](#).
2. Using a suitable suction device, remove the power steering fluid from the fluid reservoir.
3. Remove the power steering pump pulley. For additional information, refer to [Power Steering Pump Pulley](#)

— [4.6L](#), [5.4L](#) in this section.

4. Remove the pressure line bracket-to-pump stud nut.
 - To install, tighten to 7 Nm (62 lb-in).
5. Release the clamp and disconnect the power steering pump supply hose from the pump.
6. **NOTE:** A new Teflon® seal must be installed.

Disconnect the pressure line-to-pump fitting.

- Discard the Teflon® seal.
 - To install, tighten to 75 Nm (55 lb-ft).
7. Remove the 3 bolts and the power steering pump.
 - To install, tighten to 25 Nm (18 lb-ft).
 8. **NOTE:** A new Teflon® seal must be installed.

To install, reverse the removal procedure.

- Using the Teflon® Seal Installer Set, install a new Teflon® seal to the pressure line-to-pump fitting.

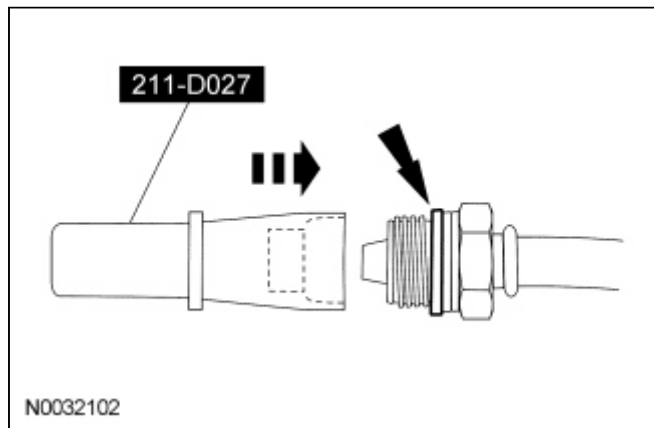

9. Fill the power steering system. For additional information, refer to [Section 211-00](#).
-